



S 1000 / 1500
E OPEN COMPRESSORS
R **OWNER'S**
I **MANUAL**
S

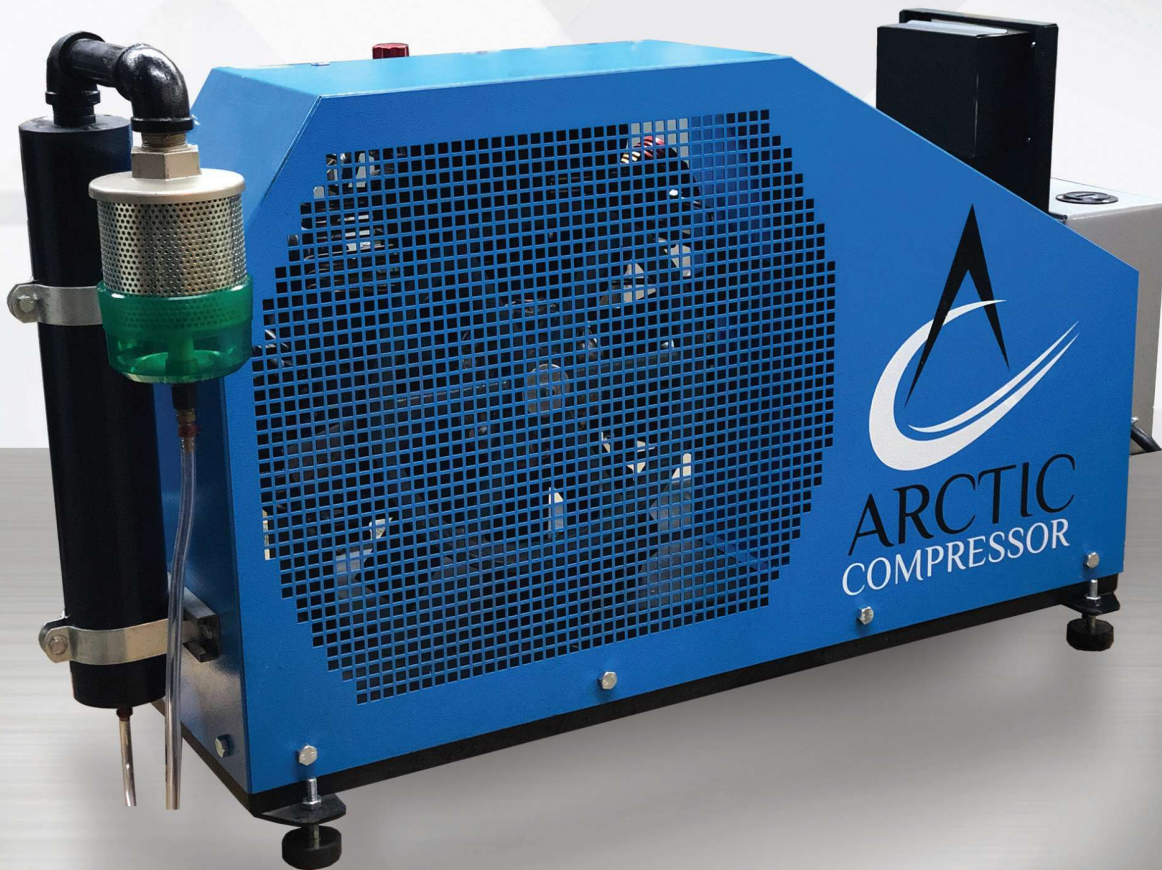

Table of Contents

<u>Section</u>	<u>Title</u>	<u>Page</u>
1	General Safety	2
	General Safety Procedures	2
	Operating and Safety Warnings	3
2	General Description	3
3	Setup	4
	Site Location	4
	Outside Air Intake	5
	Electrical Requirements	6
	Cabinet Components	7
	Start Up Procedure and Checks	8 – 9
4	General Information	10
	Air Flow Diagrams	10 - 11
	Block Component Layouts	12 - 13
5	Operation	14
	Filling Cylinders	14 - 15
	Auto Drain System	15
6	Maintenance	16
	Schedule	16
	Oil	17 - 18
	Purification Filter	19 - 21
	Air Intake Filter	22
	Belt Tension	23
	CO/Moisture Indicator Tabs	24
	Electronic CO Monitors	24
7	Technical Data	25
	Maintenance Part List	25
	Technical Data by Model	26
	Limited Warranty	27

1 Safety Information

1.1 General safety warnings.

- **READ THE MANUAL BEFORE INSTALLING AND/OR OPERATING THE COMPRESSOR.**
- Be sure to read and follow all OSHA, NEMA, ASME and local regulations, laws and codes pertaining to the installation and operation of this compressor and accessories before operating this unit.
- Be sure to follow all recommended maintenance procedures outlined in this manual. Maintenance is simple, but must be executed regularly to achieve safe operation, maximum efficiency and long service life.
- The unit must be installed, operated, maintained and repaired only by authorized, trained and qualified personnel.
- Do not operate this unit in excess of its rated capacity, pressure, or temperature. Operation of this unit in excess of the conditions set forth in this manual will subject the unit to limits which it may not be designed to withstand.
- Do not play with compressed air. Pressurized air can cause serious injuries. Cylinders filled with high pressure air should not be dropped or allowed to bump into other solid objects.
- The operator is responsible for keeping the machine in safe operating condition. If parts and accessories are not considered to be reliable for safe operation, they must be replaced immediately.
- The operator is responsible for keeping the machine in safe operating condition. If parts and accessories are not considered to be reliable for safe operation, they must be replaced immediately.
- Periodically check all safety devices, temperature and pressure gauges to make sure the system is operating within the proper limits.
- Keep the operating manual available for the operators, and take care that operation and maintenance are performed according to the instructions. Enter all operating data, executed maintenance measures, etc. in a log. Observe all relevant safety provisions.
- Failure to follow any of these warnings may result in an accident causing personal injury or property damage.
- The use of repair parts other than those provided by Arctic Compressor and approved vendors may create hazardous conditions over which Arctic Compressor has no control. Such hazardous conditions can lead to accidents that may be life threatening, cause substantial bodily injury and/or result in damage to the equipment. Therefore, Arctic Compressor can bear no responsibility for equipment in which non-approved repair parts are installed.

1.2 Specific Warnings

The following instructions must be followed to prevent serious injury or death.

- **DO NOT OPERATE THIS EQUIPMENT WITHOUT SAFETY GUARDS IN PLACE.**
- Make sure that maximum pressures are not exceeded.
- Fittings should never be adjusted while under pressure. Damaged fittings should never be used. Tubing with nicks or worn areas should never be used and should be replaced immediately.
- Damaged or bent tubing should not be repaired or straightened. It should be replaced immediately.
- Do not adjust the relief valves. The valves are specially set for the safety of the particular components.
- Before servicing or inspecting the compressor block, the electrical power supply must be disconnected.
- Suitable tubing, fittings, air receivers, storage tanks, and final stage relief valve must be utilized to accommodate the pressure produced by the compressor.
- Make sure that the air intake is receiving clean, dry air.

2 General Description

Arctic Compressors are compact air compressors, designed with high velocity composite fans and aluminum inter-coolers to provide a reliable source of high pressure air in most operating environments.

- Arctic Model 1000 series 3-stage compressors are intended to supply air for any application requiring 2000 – 5000 psi. Air delivery rates range from 5-9 CFM.
- Arctic Model 1060 series 3-stage compressors are intended to supply air for any application requiring 2000 – 6000 psi. Air delivery rates range from 5-9 CFM.
- Arctic Model 1500 series 4-stage compressors are intended to supply air for any application requiring 2000 – 6000 psi. Air delivery rates range from 9-14 CFM.

3 Setup

3.1 Unpacking

Upon receipt of the compressor, remove the packing material and inspect for damage. Take photos and contact your sales representative immediately upon any sign of problems. Compressors are shipped without filter cartridges installed. Be sure to install filter cartridges before starting compressor.

3.2 Site Location

The compressor should be located in an area with adequate ventilation. The area should be fairly clean so dust and dirt will not gather on the cooling coils or in the air intake filter, impairing proper operation of the equipment. The air intake must be placed where no toxic or unpleasant fumes are present. The air must be free from exhaust fumes, noxious gases and cleaning fumes. We recommend an outside air intake wherever possible. Temperature range of the room must be above 45° F (7° C) and below 105° F (40° C).

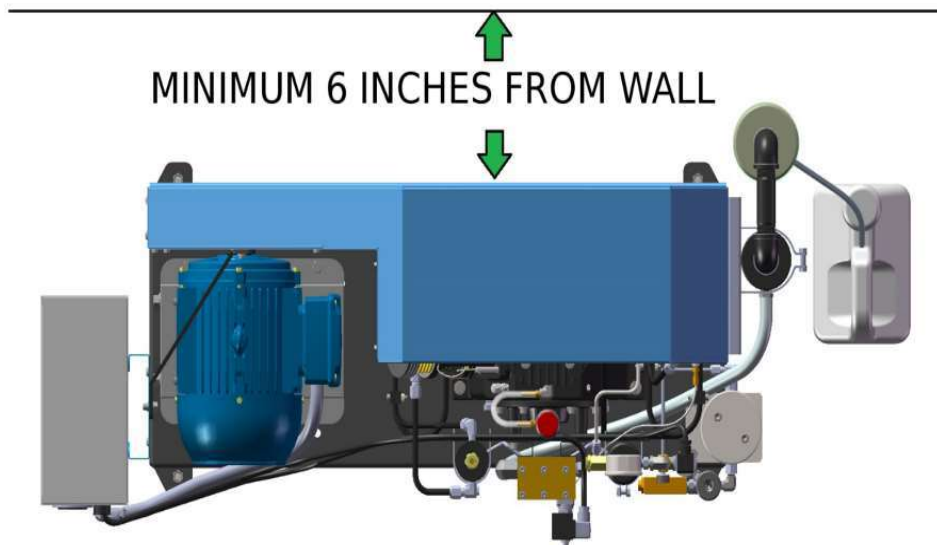

Figure 3.1

Providing adequate space around your compressor is necessary to ensure airflow for block cooling and to allow access for important maintenance steps. Placement of your compressor in a small room or closet can lead to increased unit operating temperatures and potential damage. See Figure 3.1 for examples.

3.3 Outside Air Intake.

An outside air intake can be installed as follows (see diagram 3.2)

1. Choose a location that is reasonably near the compressor and that is always low in possible contaminants. Consideration should be given to the outside environment which supplies the intake. Avoiding locations near vehicle parking, furnace exhausts, and other producers of fumes is important to the quality of your breathing air.
2. Plan the pipe routing
3. Choose pipe size: For runs of 10 feet or less use 1 1/2 PVC pipe. For runs over 10 feet, add 1/4 diameter for each additional 10 feet or portion thereof or for each 90 degree elbow.
4. Fasten piping with self tapping screws or other method of non-chemical attachment. Fumes from adhesives used in the air intake construction will affect the quality of supplied air.

NOTE: The entire length of pipe should be the same diameter. It is essential that measures be taken to preclude any water ingestion.

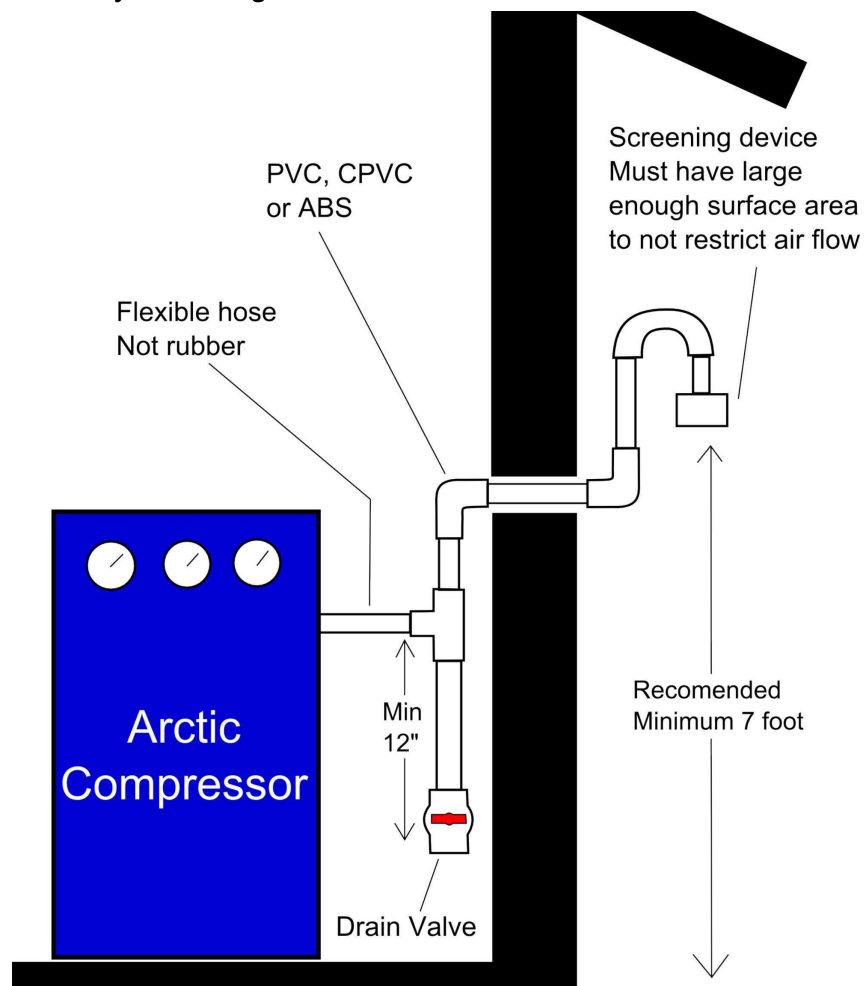

Figure 3.2

3.4 Electrical Requirements

Horse Power	Phase	Voltage	Service Amperage
5	1	220V	30 AMP
5	3	220V	20 AMP
5	3	480V	10 AMP
7.5	1	220V	50 AMP
7.5	3	220V	30 AMP
7.5	3	480V	20 AMP
10	1	220V	50 AMP
10	3	220V	30 AMP
10	3	480V	20 AMP

Table 3.1: Power Requirements

Horse Power	Single Phase 208/240V	Three Phase 208/240V	Three Phase 480V
5	NEMA 6-30	NEMA L15-20	NEMA L16-20
7.5	NEMA 6-50	NEMA L15-30	NEMA L16-20
10	NEMA 6-50	NEMA L15-30	NEMA L16-20

Table 3.2: Cord Requirements

Note: All Arctic Compressors are shipped with the appropriate cord and plug installed by the factory. This is the recommended method of electrical connection at install. Please use the tables located above to advise your electrician on the service requirements and mating receptacle.

3.5 Buildup Components

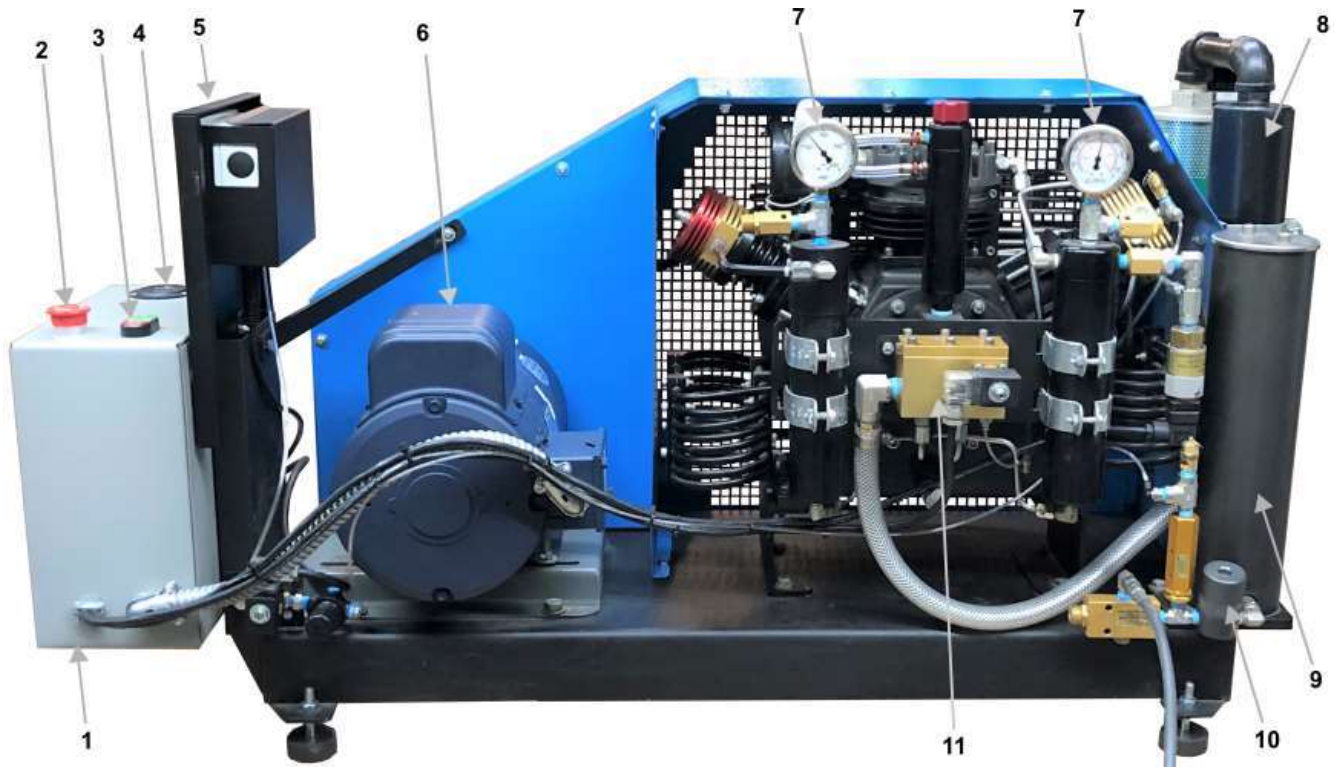

Figure 3.3

Item Number	Description	Item Number	Description
1	Electrical Box	7	Pressure Gauges
2	Emergency Stop Switch	8	Auto-Drain Silencer
3	Start / Stop Switch	9	Filter Housing
4	Hour Meter	10	Air Quality Indicator CO/Moisture
5	Electronic CO Monitor (Optional)	11	Auto-Drain
6	Motor		

Table 3.3: Buildup Components for Figure 3.3

3.6 Start Up Procedure

3.6.1 Before Starting the Compressor

- Check that there are no obstructions to the fan blades, drive belts, or air intake. (Figure 3.4 and 3.5)
- Check the oil level and add if necessary. (Figure 3.5)
- Check the CO/Moisture indicator. (Figure 3.5)
- Check the level of water in the Auto Drain condensate jug. Empty if necessary.

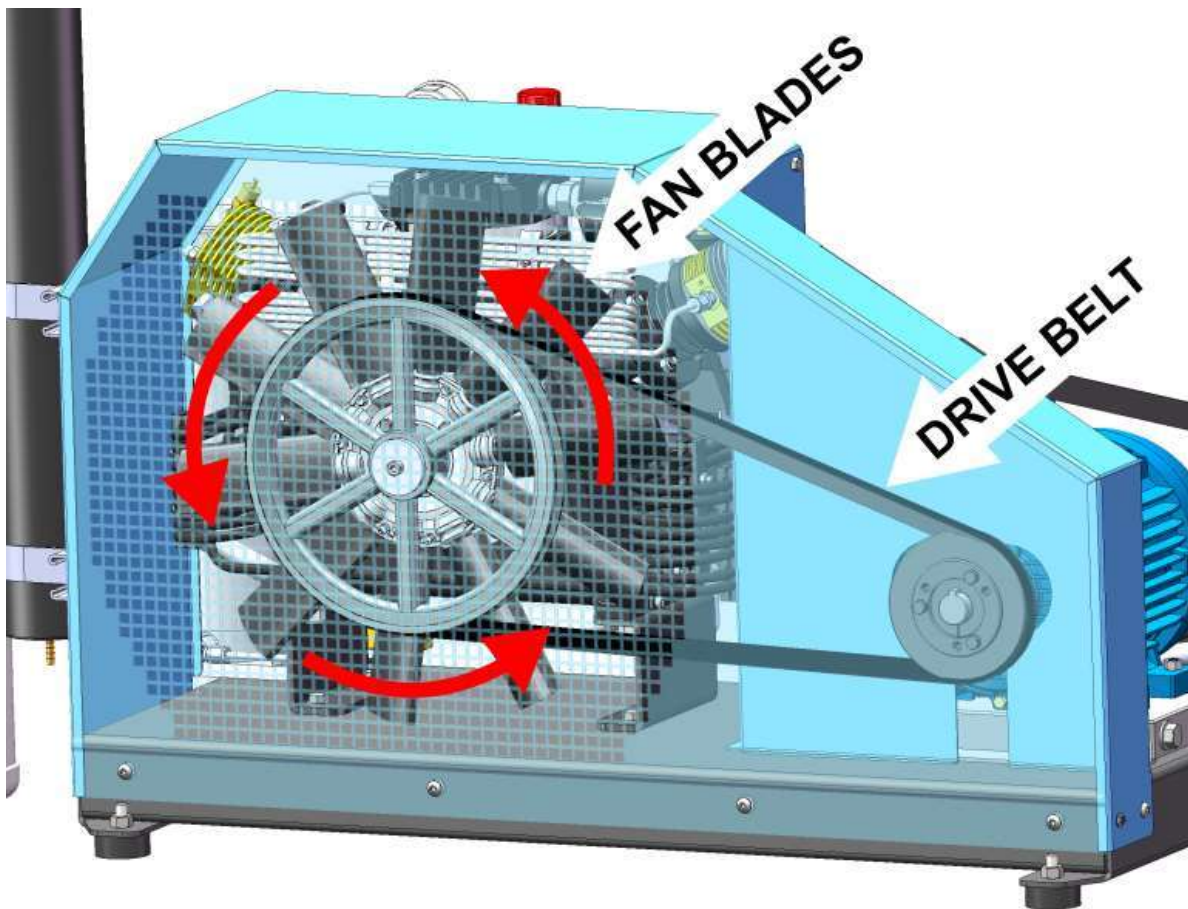

Figure 3.4: Drive Belt, Fan Blades, and Rotation

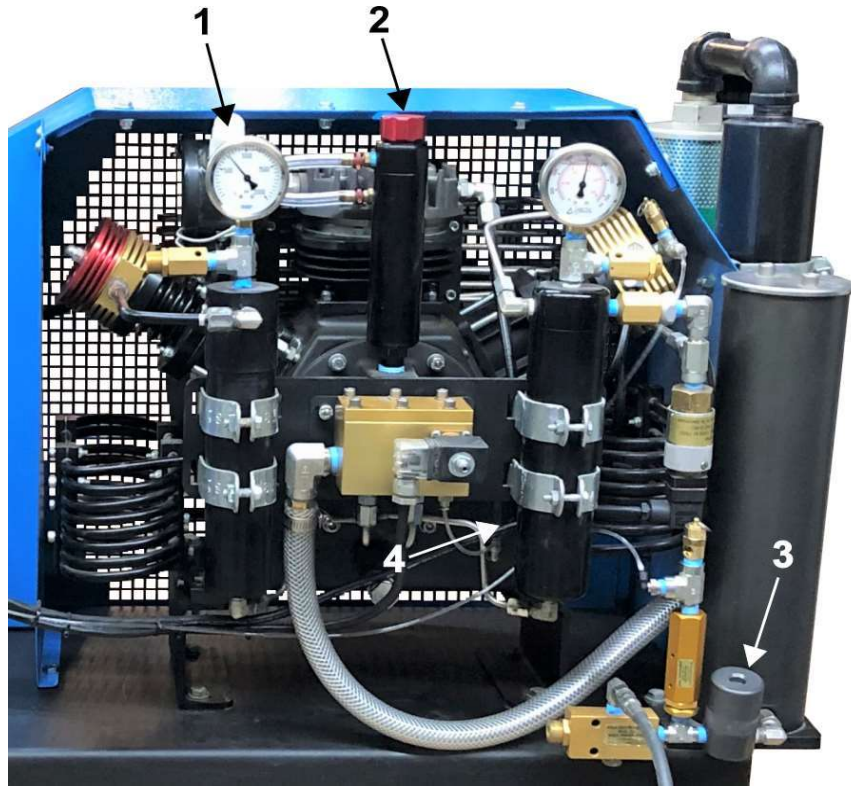

Figure 3.5: Start up Check points

Item Number	Description
1	Air Intake Filter
2	Oil Fill Cap
3	CO/ Moisture Indicator
4	Oil Level Sight Glass

Table 3.5 Block Start up point Identification, use with Figure 3.5

3.6.2 Start Up Checks

- Check the direction of rotation (Clockwise from front, counter clockwise from back). See figure 3.4.
- Stop the compressor immediately if it is going the wrong way, contact your electrician to check the installation site receptacle wiring. All compressors are tested at the factory, ensuring correct rotation.
- Check that gauges indicate normal operating ranges. See Table 5: Technical Data.

4 General Information

4.1 Airflow diagrams

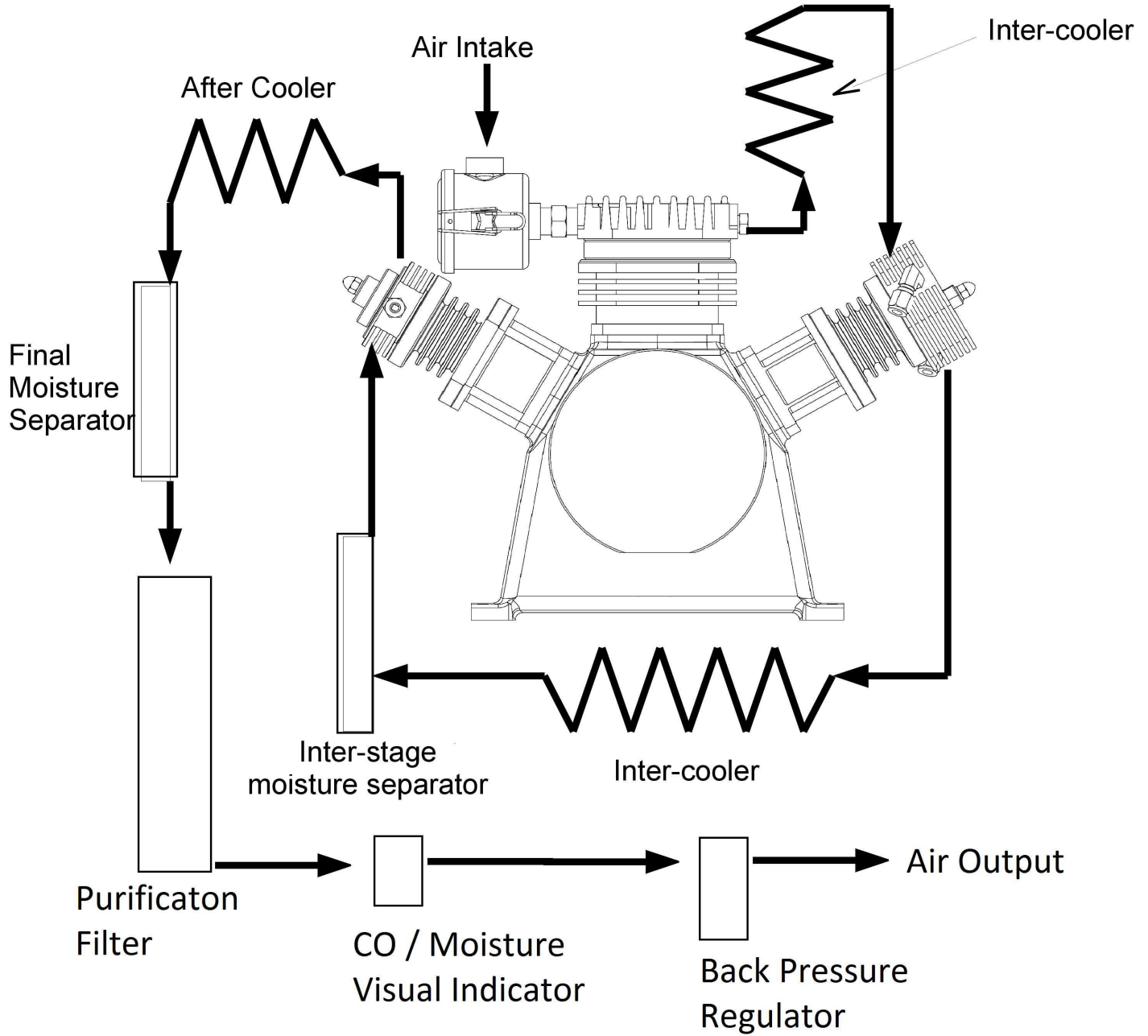

Figure 4.1: A1000/1060 Series air flow diagram

4.1 Airflow diagrams (continued)

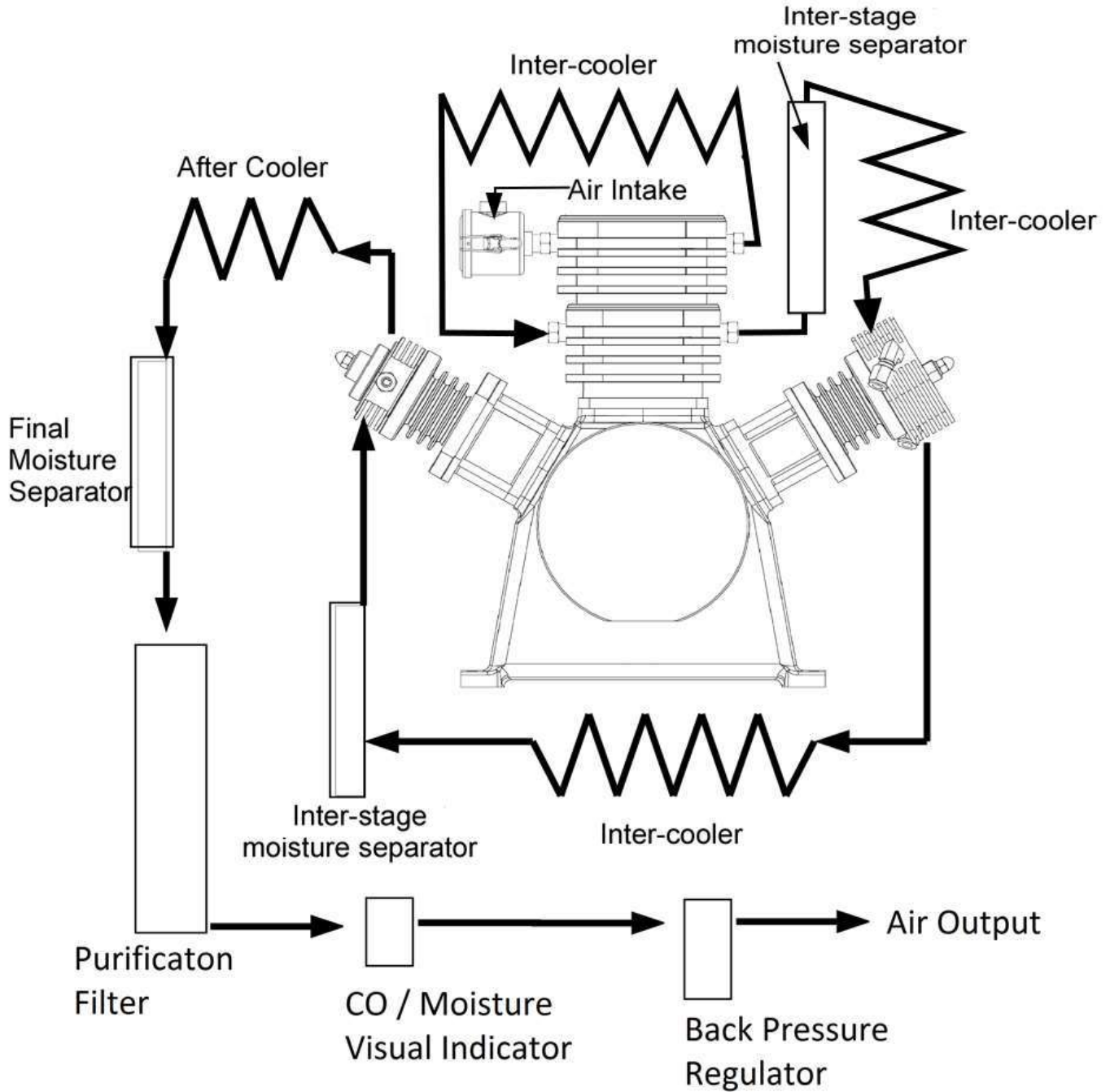

Figure 4.2: A1500 Series air flow diagram

4.2 Block Layouts

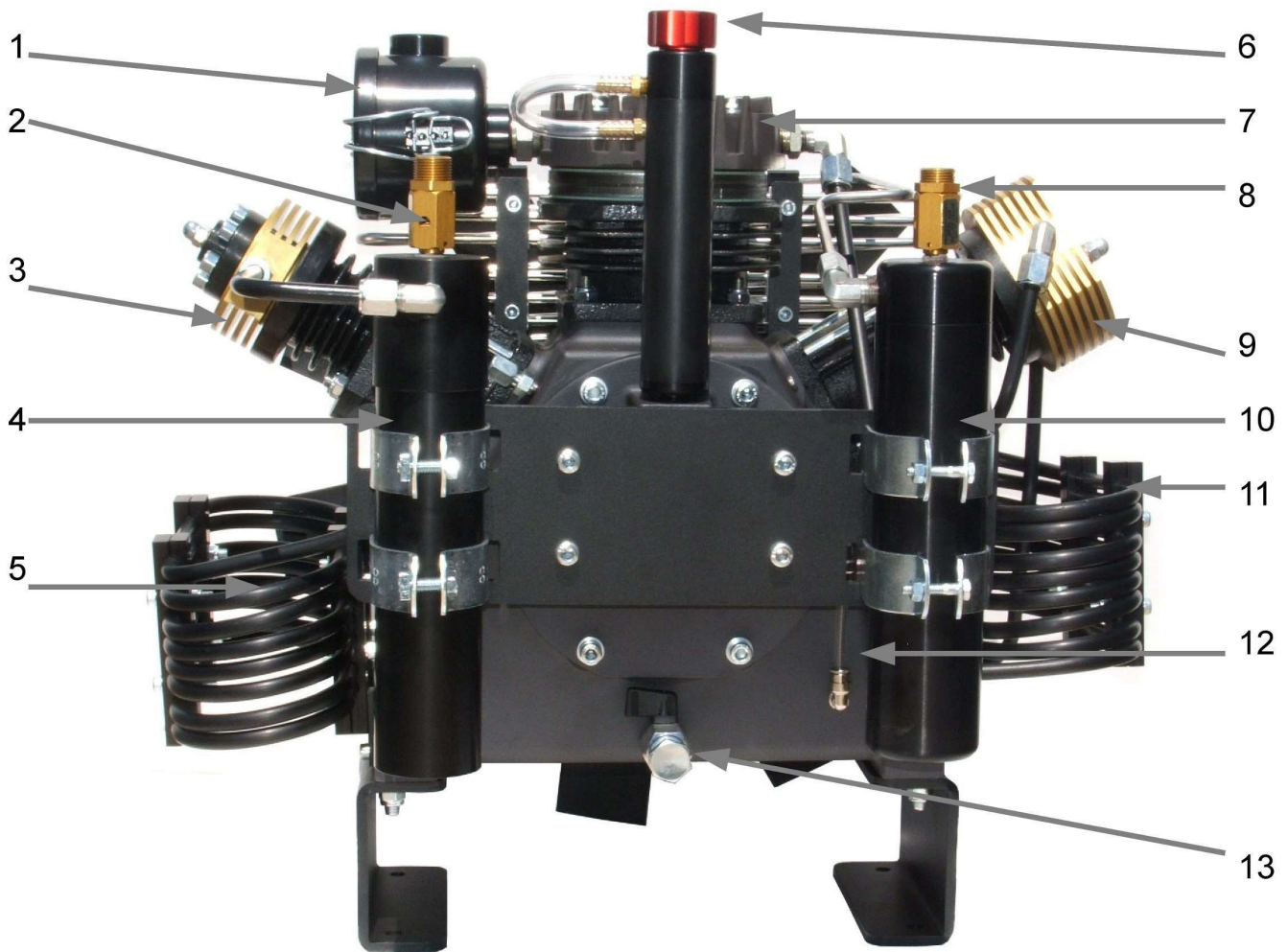

Figure 4.3: A1000/1060 Series Block Components

Item Number	Description	Item Number	Description
1	Air Intake Filter Housing	8	Final Relief Valve
2	Second Stage Relief Valve	9	Second Stage
3	Third Stage	10	Final Moisture Separator
4	Inter-Stage Moisture Separator	11	First Stage Inter-Cooler
5	Second Stage Inter-Cooler	12	Oil Level Sight Tube
6	Oil Cap	13	Oil Drain Valve
7	Final Stage		

Table 4.1: A1000/A1060 Series Block Component Descriptions

4.2 Block Layouts (continued)

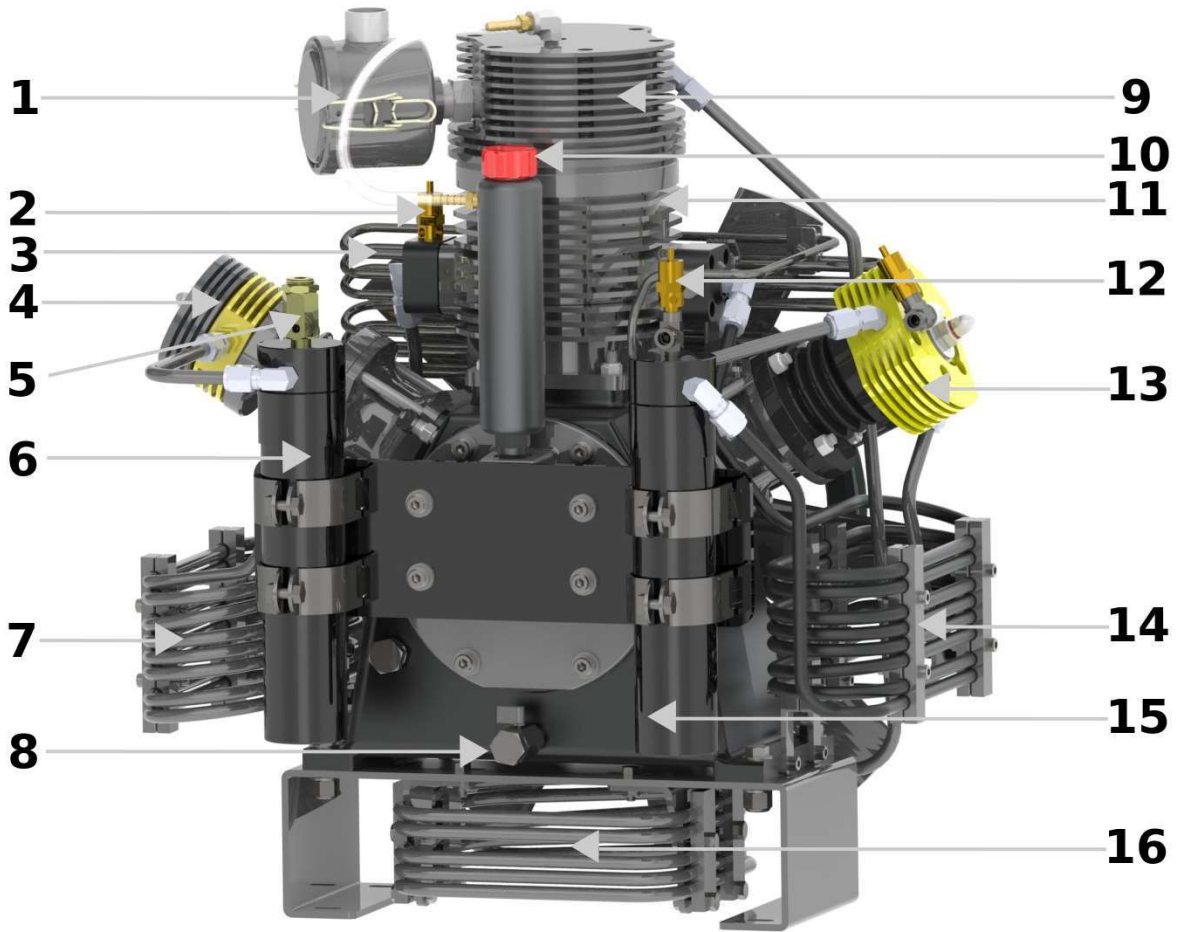

Figure 4.4: A1500 Series Block Components

Item Number	Description	Item Number	Description
1	Air Intake Filter Housing	9	First Stage
2	First Stage Relief Valve	10	Oil Cap
3	Final Cooler	11	Second Stage
4	Final Stage	12	Second Stage Relief Valve
5	Third Stage Relief Valve	13	Third Stage
6	Inter-Stage Moisture Separator	14	Second Stage Inter-Cooler
7	Third Stage Inter-Cooler	15	Inter-Stage Moisture Separator
8	Oil Drain Valve	16	First Stage Inter-Cooler

Table 4.2: A1500 Series Block Component Descriptions

5 Operation

5.1.1 Filling Cylinders Directly from Compressor.

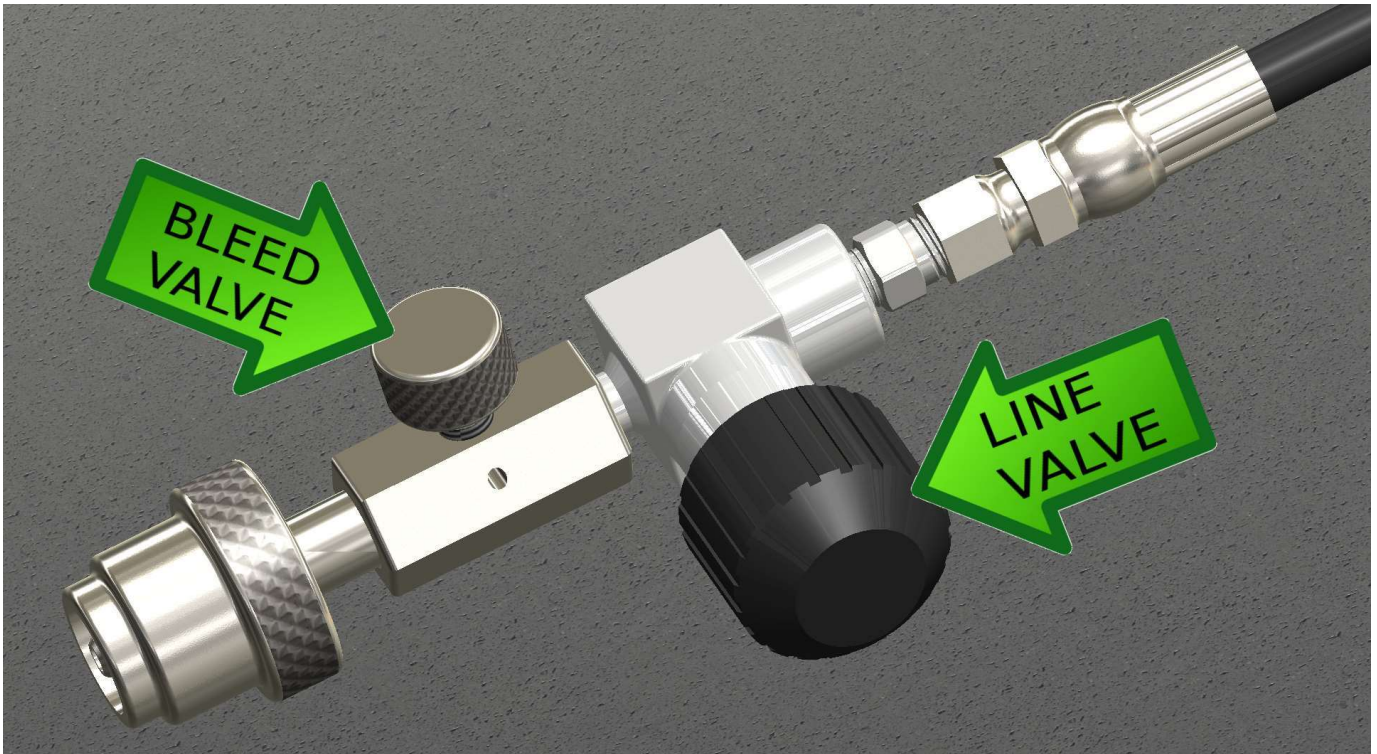

Figure 5.1: Fill Hose Components

1. Connect fill hose to cylinder to be filled.
2. Check that the Bleed valve is closed.
3. Open the line valve on the fill hose.
4. Open the valve on the cylinder to be filled.
5. Turn on the Compressor.
6. Compressors equipped with a pressure switch will shut off automatically when the cylinder is full.
7. Close the cylinder valve.
8. Close the line valve on the fill hose.
9. Open the bleed valve to allow line pressure to escape.
10. Disconnect the cylinder.

5.1.2 Filling Cylinders with additional equipment.

It is common practice to use the compressor to fill larger storage cylinders to keep compressed air readily available for on demand use. These storage systems can be paired with containment fill stations to ensure operator safety while filling cylinders. See your Containment Fill Station manual for directions on using this equipment.

5.2 Operation of Drain system

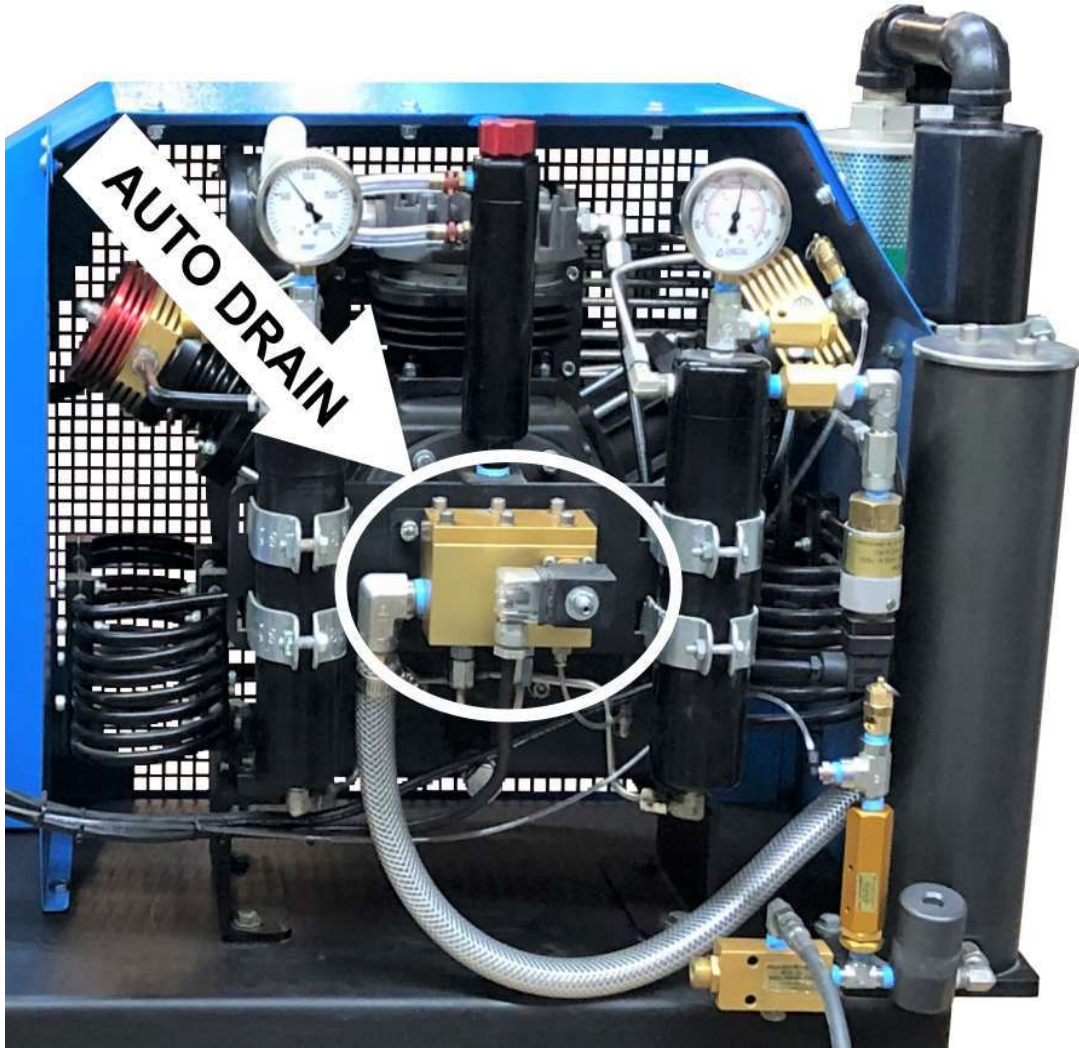

Figure 5.2: Auto Drain Identification

The compressor is equipped with an automatic drain system, a timer will activate a drain cycle every 15-20 minutes. It is common for the condensate to have a milky color and contain a small amount of oil. If a large amount of oil is present passed the initial break in period of operation, the compressor should be serviced by a trained technician.

6 Maintenance

6.1 Maintenance Schedule

Maintenance	Each Fill	Daily	Every 6 Months	Every Year	>2 years	25 hr	40 hr	125 hr	250 hr	500 hr	1000 hr	3000 hr
Check Oil Level/ Operating pressure		X										
Check condensate container		X										
Check auto drain system		X										
Check CO/Moisture Indicator		X										
Calibrate Electronic CO Monitor			Suggested	Required								
Electronic CO Sensor Replacement					Possible*							
First Oil Change						X						
Change Oil				X					X			
Air intake filter								Rotate		X		
Air Filter							X					
Check Fittings & Hoses for leaks				X					X			
Check V-belt tensions				X					X			
Final stage valve replacement										X		
1st, 2nd, and 3rd stage valve replacement											X	
Moisture separator replacement												X
Filter housing replacement												X

Table 6.1: 1000 Series Maintenance Schedule

The Electronic CO Monitor Sensor is guaranteed for a 2 year period. If the monitor will not calibrate after this 2 year period, the sensor may need to be replaced.

NOTE: This Compressor produces a considerable amount of heat. Make sure the compressor has cooled before attempting to carry out maintenance activities. **All Maintenance work must take place with the compressor OFF and the power supply disconnected.**

6.2 Checking the Oil Level

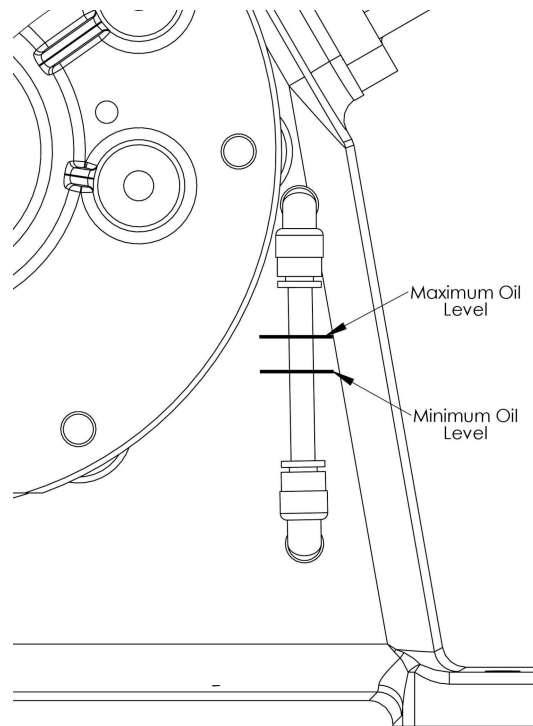

Figure 6.1: Oil Fill Level

The Compressor oil level must be checked daily. The oil level must read between the minimum and the maximum lines shown on the sight tube. (Figure 6.1)

If the oil level is below the minimum level:

1. Open the oil fill cap (Figures 4.3 and 4.4)
2. Add oil until the level reaches the maximum line on the sight tube. Pour slowly and check the level frequently while filling. Oil levels can register slowly while filling. Take care not to overfill.
3. Close the oil fill cap.

If the oil level is above the maximum level:

1. Position a pan below the oil drain (figures 4.3 and 4.3)
2. remove the drain plug and open the drain valve $\frac{1}{4}$ turn.
3. Let the oil drain out until the level returns to the acceptable range.
4. Close the drain valve and replace the plug.

NOTE: Oil should be disposed of in accordance with local laws.

6.3 Changing the Oil

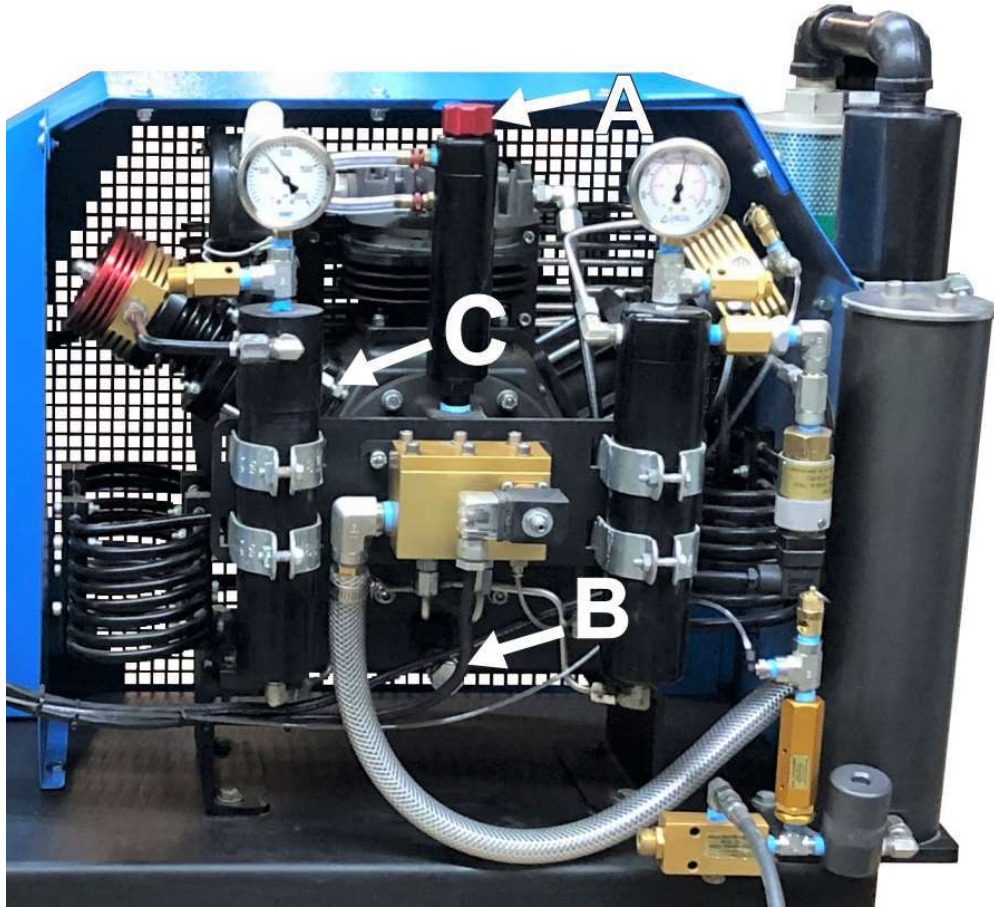

Figure 6.2 Oil Drain, Fill Cap, and Crankcase Vent Locations

Use only high grade synthetic compressor oil.

6.3.1 Draining Oil

1. Make sure the power is disconnected and the compressor is cool.
2. Place drain pan under the drain. (“B” Figure 6.2)
3. Remove the plug and open the drain valve $\frac{1}{4}$ turn.
4. Allow all oil to drain from reservoir. Open Fill cap (“A” Figure 6.2) to speed draining.
5. Close Drain valve and replace Plug.

6.3.2 Adding Oil

1. Remove the cap from the crankcase vent to allow air to escape as oil is added (“C” Figure 6.2)
2. Remove the Oil Fill Cap (“A” Figure 6.2) Refill the oil reservoir slowly, allowing oil to settle before checking sight tube.
3. Once the sight tube reads at the maximum, replace oil fill cap and crankcase vent cap.

6.4 Changing the Purification Filter

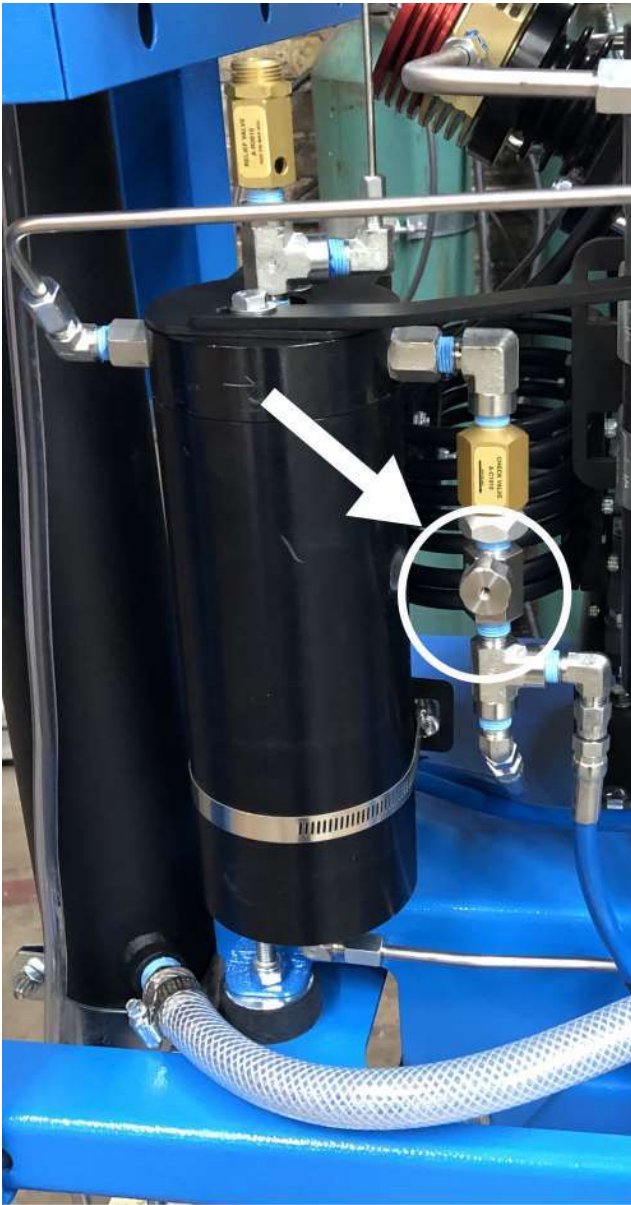

Figure 6.3: A1500 Series Bleed Valve



Figure 6.4: A1000/1060 Series Bleed Valve

6.4.1 Bleed Filter Chamber Pressure

- Make sure the power is disconnected and the compressor is cool.
- **Slowly** release pressure from the filter chamber by opening the bleed valve. If filter pressure is released too fast, the cartridge could be damaged.

6.4.2 Removing the Filter Chamber Cap

NOTE: If the filter chamber is not bled of pressure prior to attempting to change the filter the chamber top will be extremely difficult to turn. If the chamber top seems difficult to remove, **STOP** and double check that the filtration system has been bled of all pressure.



Figure 6.5: Cap removal with Screwdriver



Figure 6.6: Cap Removal with Filter Wrench

- Open the top of the filter chamber using a specialty filter wrench or by spanning the two bolts with a large screwdriver or wrench handle (Figure 6.6)

The entire cap will unscrew from the body of the chamber. **Do not remove the two bolts from the dust cap.**

6.4.3 Replacing the Filter



Figure 6.7 Filter cartridge removal.

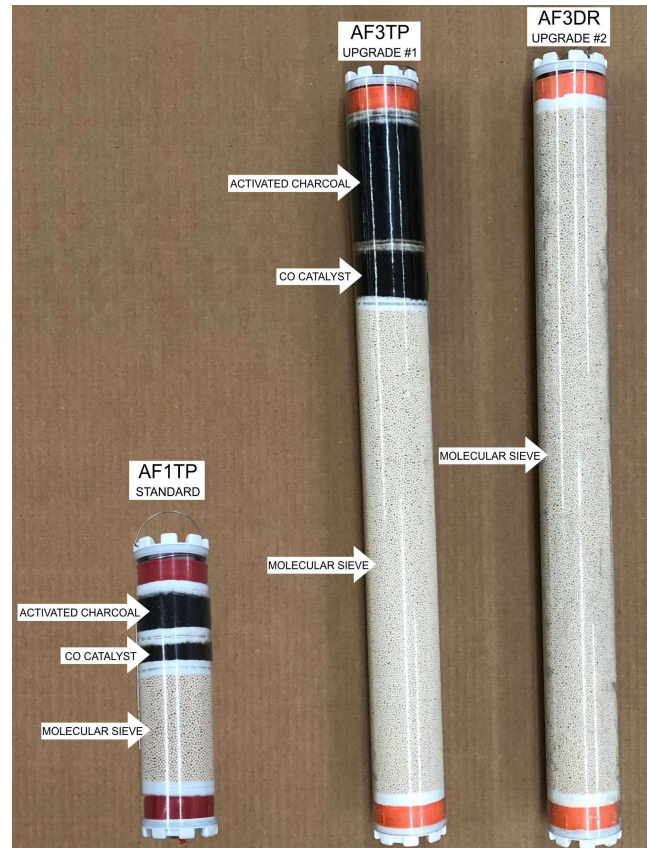

Figure 6.8: Filter Types

1. Remove the expired filter cartridge.
2. Use a light to inspect the filter tube interior for moisture or remaining pieces of filter cartridge that may have broken off during removal. Remove any moisture or debris if present.
3. **Gently** insert a new filter cartridge. Make sure any protective caps or barriers are removed from the cartridge prior to install to allow proper air flow through the filter media. Take care not to drop or bang the cartridge in the filter chamber. This can damage the new filter.
4. Press down on the filter cartridge to ensure it is properly seated in the filter housing.

Note: If your Compressor is equipped with a second optional filter, make sure the cartridges are installed in the correct order. The standard filter cartridge has three layers: Activated Charcoal, CO Catalyst, and Molecular Sieve. The Optional Pre-filter drier cartridge contains only molecular sieve. This extends the life of the standard filter. The pre-filter must be installed in the first chamber. Open frame models come standard with a 1lb filter. Upgrades are available.

5. Replace Filter Cap.
6. Close Bleed Valve.

6.5 Changing the Intake Air Filter

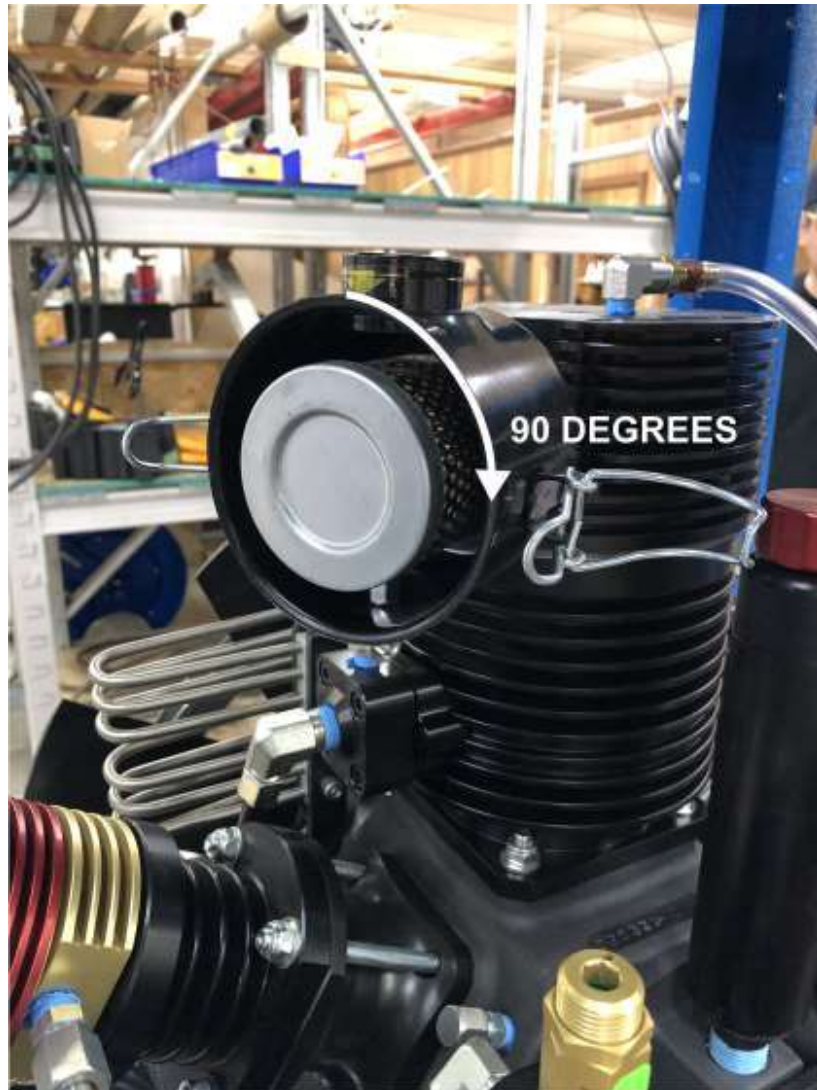

Figure 6.9: Air Intake filter rotation

The intake air filter should be rotated every 125 hours and replaced every 500 hours. This is a 20 micron filter.

1. Locate the intake filter housing. (Figure 4.3 and 4.4)
2. Remove the cover by releasing the two retaining levers.
3. Replace pleated filter and reinstall the cover.
4. Every 125 working hours rotate the filtration cartridge 90 degrees. (Figure 6.9)

6.6 Checking the Belt Tension

To check for proper drive belt tension exert a pressure of appropriately 22 lbs. (10 Kg) on the belt. (Figure 3.4) Check that the belt(s) do not flex by more than 3/8" (1 cm) in respect to the original position.

Should they flex by more than 3/8", the belt tension should be adjusted or the belt replaced if necessary.



Figure 6.10: Open Frame Belt Tension Bolts

To Adjust drive belt tension:

1. Locate the Drive belt tensioner bolts, located next to the Motor.
2. Loosen the **Top Jamb Nuts** to allow motor movement.
3. Turn the **Adjustment bolts** on the bottom of the motor mounting plate to either increase or decrease tension.
4. Once desired belt tension is reached, re-tighten **Top Jamb Nuts**.

6.7 Replacing CO / Moisture Visual Indicator Tab

This visual indicator should be checked everyday that the compressor is in use to ensure that the system does not contain excess Moisture or CO. These tabs are an indicator on the status of your air filter. If high CO or Moisture is indicated, contact your factory trained Service Technician.

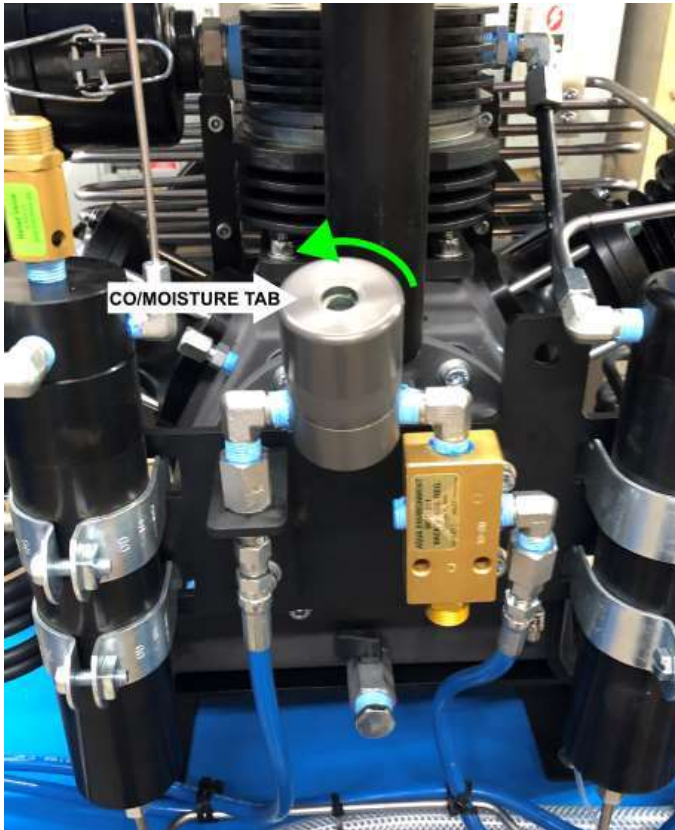

Figure 6.11: CO/Moisture Tab Sight Glass.

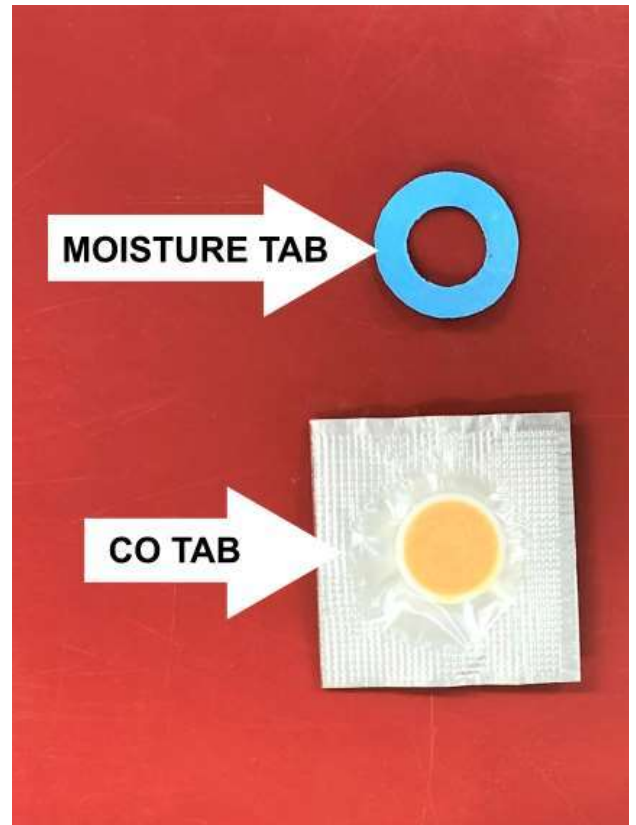

Figure 6.12: New CO and Moisture Tabs.

To Change CO/ Moisture indicator tab:

1. Unscrew the top portion of the sight glass enclosure to access the tabs. (Figure 6.11)
2. Replace with fresh CO and Moisture tabs. (Figure 6.12)
3. Screw the top of the enclosure back into place.

6.8 Calibrating Optional Electronic CO Monitor

Electronic CO Monitor (Figure 3.3) calibration is recommended every 6 months and required every year. See your CO Monitor Manual for calibration instructions.

7 Technical Data

Maintenance Part	Part #	Description
Standard 1lb purification filter	AF1TP	Activated Charcoal, CO catalyst, and Molecular sieve
Expanded 3lb purification filter	AF3TP	Activated Charcoal, CO catalyst, and Molecular sieve
Optional 3lb purification pre-filter	AF3DR	Molecular sieve only
CO/ Moisture Indicator Tab	X-TABS	Permanently changes color indicating poor air quality
Intake Filter	X-AI-2	First stage intake air filter
Compressor Oil	O-S501100	1 gallon

Table 7.1: Maintenance Parts and Descriptions

Compressor Block	Arctic 1000	Arctic 1060	Arctic 1500
Operating Pressure	5000 PSI Max	6000 PSI Max	6000 PSI Max
Delivery with 5 HP motor	5 CFM FAD (6.5 CFM Charge Rate)	4.75 CFM FAD (6 CFM Charge Rate)	N/A
Delivery with 7.5 HP motor	7.5 CFM FAD (9 CFM Charge Rate)	6.5 CFM FAD (8 CFM Charge Rate)	7.75 CFM FAD (9 CFM Charge Rate)
Delivery with 10 HP motor	N/A	N/A	12 CFM FAD (14 CFM Charge Rate)
Number of Stages	3	3	4
Number of Cylinders	3	3	4
First Stage Bore	3.543" (90mm)	3.543" (90mm)	4.134" (105mm)
Second Stage Bore	1.417" (36mm)	1.417" (36mm)	3.465" (88mm)
Third Stage Bore	0.551" (14mm)	0.472" (12mm)	1.102" (28mm)
Fourth Stage Bore	N/A	N/A	0.472" (12mm)
Piston Stroke	1.575" (40mm)	1.575" (40mm)	1.575" (40mm)
First Stage Pressure	60-80 PSI	85-95 PSI	60-80 PSI
Second Stage Pressure	550-675 PSI	700-850 PSI	225-275 PSI
Third Stage Pressure	Max 5000 PSI	Max 6000 PSI	1200-1300 PSI
Fourth Stage Pressure	N/A	N/A	Max 6000 PSI
First Stage Relief Valve	150 PSI	200 PSI	150 PSI
Second Stage Relief Valve	850 PSI	1000 PSI	300 PSI
Third Stage Relief Valve	10% above operating pressure (Max 5500 PSI)	10% above operating pressure (Max 6600 PSI)	1500 PSI
Fourth Stage Relief Valve	N/A	N/A	10% above operating pressure (Max 6600 PSI)
Oil Capacity	3qt	3qt	3qt
Oil Type	Chemlube 501, Mobile Rarus 827, or equivalent.	Chemlube 501, Mobile Rarus 827, or equivalent.	Chemlube 501, Mobile Rarus 827, or equivalent.
Lubrication	Splash Lubrication	Splash Lubrication	Splash Lubrication
Maximum Inclination	5°	5°	5°
Ambient Temperature	45° F- 105° F Max	45° F- 105° F Max	45° F- 105° F Max
Rotation Speed with 5 HP Motor	1000 RPM	1000 RPM	N/A
Rotation Speed with 7.5 HP Motor	1500 RPM	1500 RPM	1100 RPM
Rotation Speed with 10 HP Motor	N/A	N/A	1400 RPM
Rotation Direction	CCW from flywheel side	CCW from flywheel side	CCW from flywheel side

Table 7.2 Technical Data by Model

Limited Warranty **Arctic Compressor, LLC**

1 Warranty Coverage

Arctic Compressor, LLC (“Seller”) warrants to the original purchaser (“Buyer”) that all new equipment manufactured and delivered by Seller (“Product”) shall be free from defects in material or workmanship for a period of two (2) year from the date of delivery or for up to 500 hours of Product operation, whichever occurs first (“Warranty Period”). During the Warranty Period, Seller will at its option provide suitable repair or replacement of a defective Product. In the event Seller opts to repair the Product, Seller may use new or refurbished replacement parts. In the event Seller opts to replace the Product, Seller reserves the right to provide an equivalent product when unable to provide an exact replacement.

2 Limitations

This warranty is valid to the Buyer only and is non-transferable. This warranty is contingent upon Buyer’s proper storage, installation, maintenance, and operation of the Product in accordance with standard industry practices, and Buyer’s compliance with any and all specific recommendations of Seller. Buyer’s failure to comply with any maintenance schedules provided in Product manuals shall void all coverage for defects under this warranty.

This limited warranty shall not apply to and Seller shall not be liable for:

- The effects of corrosion, erosion and normal wear and tear; or
- Damage due to fire, floods, acts of God, accidents, improper installation, abnormal or unattended operation, neglect or damage incurred in transit; or
- Repairs, replacements or adjustments to the Product performed by the Buyer or others without prior written approval from Seller; or
- Expendable materials, including but not limited to, filter cartridges, oil, and oil filters; or
- Products purchased or used outside of the United.

3 Warranty Service Claims

Notice of any known defect shall be provided to Seller in writing by mail within thirty (30) days of discovery during the warranty period. Buyer’s written notification shall be mailed to the following address: Arctic Compressor, LLC, 431 Tower Avenue, Superior, WI 54880. Buyer’s written notification shall identify the known defect, as well as identify the serial number, model number, and delivery date of the Product requiring warranty services. If requested by the Seller, the defective Product or portion thereof must be promptly delivered to Seller for inspection at Buyer’s sole cost and expense. Buyer assumes all risk and liability that may arise from the use of the defective Product following the discovery of any alleged defect, and such use shall void this warranty.

4 Disclaimer

This warranty is Seller’s sole warranty and any and all other warranties, expressed or implied, including any warranties of merchantability and fitness for particular purpose, are hereby specifically excluded, provided however, that Seller at its sole discretion may offer an extended warranty program, which the Buyer may purchase for additional warranty protection. Seller’s liability for any loss or damage arising out of, or resulting from, or in any way connected with the Product shall not exceed Buyer’s purchase price for the particular Product upon which such liability is based, regardless of whether such liability arises in contract, tort or otherwise. In no event shall the Seller be liable for incidental, consequential, indirect, special or punitive damages resulting from the use of the Product. Correction of any defect, in the manner and for the time period stated above, shall constitute fulfillment of all liabilities of Seller.



Arctic Compressor, LLC.

431 Tower Avenue, Superior, WI 54880



(715) 718-3065



info@arcticcompressor.com